

Sanicom 1

Sanicom 1 is an automatic powerful lifting station for grey water and can be used in commercial applications. Suitable for multiple connections this unit can handle temperatures up to 90 degrees for short periods of time.



11 m
↑



See page 10

PRODUCT BENEFITS

- Grey water lifting station
- The unit is floor standing for easy installation
- Easily accessibility for maintenance
- 2 side inlets
- Alarm can be fitted to the unit if required

PACKAGING

Sanicom 1, non-return valve

OPTIONAL EXTRAS

Wired, audible and visual alarm box
Barcode: 3308815083384
Product code: 30520



CONNECTIONS

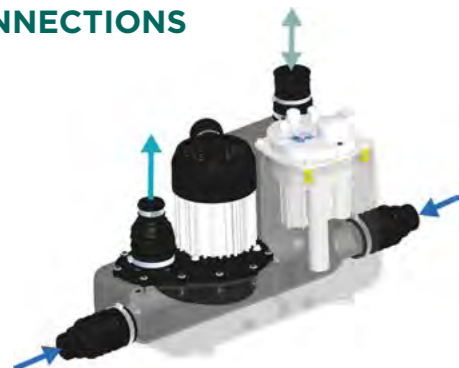

- ➔ External inlet diameter: 40/50 mm
- ➔ External discharge diameter: 32 mm
- ↔ External ventilation diameter: 50 mm

DIMENSIONS

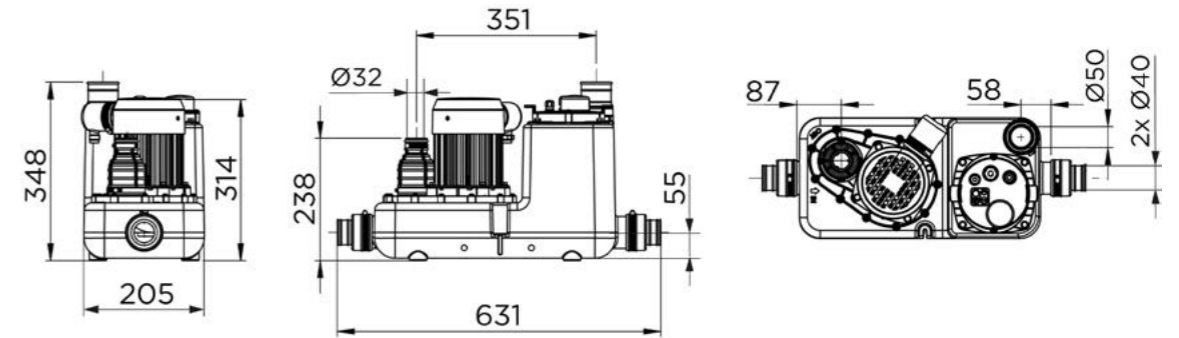

CURVE

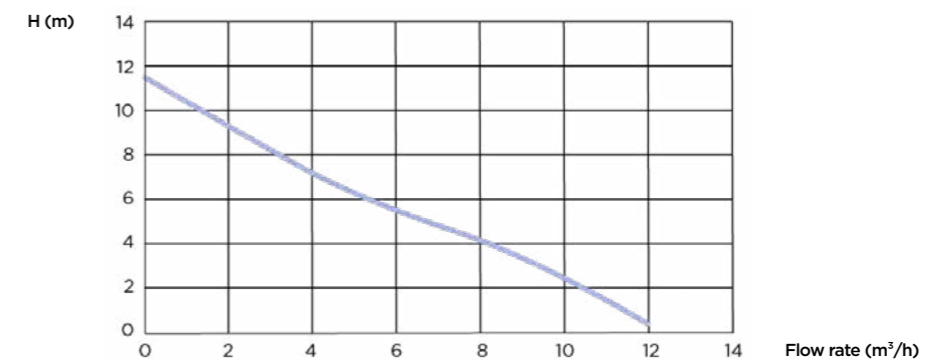

	Sanicom 1
Type of control box	Integrated
Material	
Tank	PE
Pump housing	PA 12 GF
Motor housing	Aluminium
Impeller	PA 6 GF
Electrical features	
Voltage (V)	230
Frequency (Hz)	50-60
Power consumption P1 (W)	750
Power output P2 (W)	525
IP rating	IPX4
Hydraulics	
Total head (m)	11
Max. flow rate (m³/h)	12
External inlet diameter (mm)	40/50
External discharge diameter (mm)	32
External ventilation diameter (mm)	50
Total volume (L)	14
Useable volume (L)	5.7
ON level /OFF level (mm)	135/50
Alarm level (mm)	205
Particle size (mm)	8
Max. temperature of the pumped liquid (5 min)	90°C
Type of impeller	multi-channel
Type of activation	pneumatic
Identification and logistics	
Gross weight (kg)	11.5
Barcode	3308815082851
Product code	30003